

ohne Längenausgleich auf Druck und Zug

Quick change tapping chucks **without** length compensation on compression and expansion

Mandrins de taraudage à changement rapide **sans** compensation longitudinale à la compression et traction



Verwendung:
Zur Aufnahme von Schnellwechsel-Einsätzen für Gewindebohrer.

Application:
For the chucking of quick change adaptors for taps.

Application:
Pour le serrage d'adapteurs portetarauds à changement rapide.

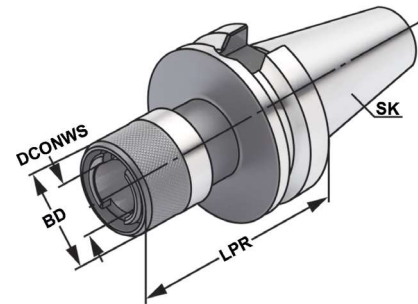

ISO 7388-2

Form JD (AD)

13.04

| Bestell-Nr. Order no. Référence | SK | Spannbereich Capacity Capacité | SZID | DCONWS | LPR | BD |
|---------------------------------------|-------|--------------------------------------|------|--------|-----|----|
| 305.16.12.1 | BT 30 | M3 – M14 | 1 | 19 | 66 | 38 |
| 305.16.20.1 | BT 30 | M5 – M22 | 2 | 31 | 80 | 54 |
| 405.16.12.1 | BT 40 | M3 – M14 | 1 | 19 | 72 | 38 |
| 405.16.20.1 | BT 40 | M5 – M22 | 2 | 31 | 93 | 54 |
| 405.16.36.1 | BT 40 | M14 – M36 | 3 | 48 | 130 | 78 |
| 505.16.12.1 | BT 50 | M3 – M14 | 1 | 19 | 80 | 38 |
| 505.16.20.1 | BT 50 | M5 – M22 | 2 | 31 | 95 | 54 |
| 505.16.36.1 | BT 50 | M14 – M36 | 3 | 48 | 142 | 78 |

Hinweis: Für Bearbeitungszentren mit Synchronspindel.
Note: For machining centres with synchronous spindle.
Observation: Pour centres d'usinage avec broche synchrone.

